

C.S-20-218

**AMENDED**  
**CHANGE ORDER APPROVAL FORM**  
(TO REFLECT ADDITIONAL COMPENSATION)

PROJECT: County Road 115 Road Improvements

CHANGE ORDER NUMBER: 4

DATE: 6/01/2021

CONTRACT NUMBER: CM2731

TO CONTRACTOR: Anderson Columbia Co. Inc.

Reason for Change Order:

Description: The undersigned parties agree to amend this Contract by compensating the Contractor \$5,151.76 and 5 Contract days for installation of a yard drain at Sta. 18+85 RT. This change order represents complete compensation for all labor, equipment, material, and any other incidental costs associated with this work.

Reason: Due to the citizens complaint of ponding at 450476 Old Dixie Hwy property, the Contractor was directed to proceed with installation of an 8" yard drain and add 4-5' of pipe from the ROW to connect into the new installed 24" RCP on 3/3/21. It should also be noted the property owner agreed to dig a ditch from his yard to the ROW and maintain the yard drain.

Original Contract Sum.....	\$ 6,769,323.25
Net Change by Previous Change Order/Supplemental Agreement.	\$ 645,633.16
Contract Sum Prior to This Change Order.....	\$ 7,414,956.41
 Amount of This Change Order (Add).....	 \$ <u>5,151.76</u>
 New Contract Sum Including this Change Order.....	 \$ <u>7,420,108.17</u>

The Contract Time will be increased	<u>5 (Five) days</u>
Previous estimated Substantial Completion: <u>12/16/2020</u>	Final Completion: <u>01/30/2021</u>
New estimated Substantial Completion: <u>12/21/2020</u>	Final Completion: <u>02/04/2021</u>

APPROVED BY: <u>Robert Companion</u> Robert Companion, Engineering Services	DATE: <u>6/2/2021</u>
APPROVED BY: <u>[Signature]</u> Brian Simmons, Procurement Manager	DATE: <u>6/3/2021</u>
APPROVED BY: <u>Megan Diehl</u> Megan Diehl, Office of Management and Budget	DATE: <u>6/3/2021</u>
APPROVED BY: <u>Michael S. Mullin</u> Michael Mullin, County Atty.	DATE: <u>6/3/2021</u>

APPROVED BY: Taco E. Pope, AICP  
Taco E. Pope, AICP, County Manager

DATE: 6/3/2021

APPROVED BY: N/A  
Thomas R. Ford, Chairman

DATE: \_\_\_\_\_

ATTEST: N/A  
John A. Crawford, Clerk of Courts

DATE: \_\_\_\_\_

Account No(s). **63470541-563100 115SB**

Invitation to Bid

Road Improvements for CR 115

NC19-015

**SECTION 00 63 63**

**CHANGE ORDER REQUEST FORM**

Change Order No. 04

PROJECT CR-115 Road Improvement

DATE OF ISSUANCE 4/16/2021

EFFECTIVE DATE 4/16/2021

NASSAU COUNTY BOARD OF COUNTY COMMISSIONERS

COUNTY Contract / Purchase Order No.: CM2731

CONTRACTOR- Anderson Columbia Co., Inc.

ENGINEER / ARCHITECT- Elton Albin

You are directed to make the following changes in the Contract Documents

The undersigned parties agree to amend this Contract by compensating the Contractor \$5,151.76 and 5 Contract days for installation of a yard drain at Sta. 18+85 RT. This change order represents complete compensation for all labor, equipment, material, and any other incidental costs associated with this work (Cont. pg 2)

Attachments: (List documents supporting change) Email correspondence, DWR, Photos, and Contract Time Tracking Log

<p>CHANGE IN CONTRACT PRICE:</p> <p>Original Contract Price \$ 6,769,323.25</p>	<p>CHANGE IN CONTRACT TIMES:</p> <p>Original Contract Times 295 (Substantial) / 340 (Final)</p> <p>Ready for Final Payment: 295 (9/14/20) / 340 (10/29/20) (days or dates)</p>
<p>Net change from previous Change Orders No. 01 to No. 03 \$ 645,633.16</p>	<p>Net change from previous Change Orders No. 01 to No. 03 93 (ninety-three) (days)</p>
<p>Contract Price prior to this Change Order \$ 7,414,956.41</p>	<p>Contract Times Prior to this Change Order</p> <p>Substantial Completion: 388 (12/16/20)</p> <p>Ready for Final Payment: 433 (1/30/21) (days or dates)</p>
<p>Net Increase (decrease) of this Change Order \$ 5,151.76</p>	<p>Net Increase (decrease) of this Change Order 5 (five) (days)</p>
<p>Contract Price with all approved Change Orders \$ 7,420,108.17</p>	<p>Contract Times with all approved Change Orders</p> <p>Substantial Completion: 393 (12/21/20)</p> <p>Ready for Final Payment: 438 (2/4/21) (days or dates)</p>

RECOMMENDED  
By:   
Engineer/Architect (Authorized Signature)

APPROVED:  
By:   
COUNTY (Authorized Signature)

ACCEPTED  
By:   
Contractor (Authorized Signature)

Date:

Date:

Date:

Change Order No. 02  
 CR-115 Road Improvement  
 CM2731  
 December 18, 2020

Cont. from pg 1:

Reason: Due to the citizens complaint of ponding at 450476 Old Dixie Hwy property, the Contractor was directed to proceed with installation of an 8" yard drain and add 4-5' of pipe from the ROW to connect into the newly installed 24" RCP on 3/3/21. It should also be noted the property owner agreed to dig a ditch from his yard to the ROW and maintain the yard drain.

Description of Extension	Weather Days Granted	Other Granted Days	Total Days Granted	Remarks
Weather / Holiday Letter Nov 25th thru Dec 31st 2019	2	8	10	Weather - 12/22 and 12/28 and Holiday - 11/27, 11/28, 11/29, 11/30, 12/1, 12/24, 12/25, 12/31
Weather / Holiday Letter Dec 31st thru Jan 15th 2020	1	1	12	Weather - 1/4 and Holiday - 1/1
Weather / Holiday Letter Jan 20th thru Feb 10th 2020	3	0	15	Weather - 1/31, 2/7, 2/14 and Holiday - 0
CO No. 1		15	30	Delay of Work from Mar Jrd thru Mar 18th 2020 (Board Meeting)
CO No. 1		2	32	Increased Milling Depth from 15-00 to 196-00
CO No. 1		4	36	Leveling Course to Correct Ruting from 196-00 to 420-96-52
CO No. 1		4	40	2" Overlay for Cyal Road
Weather / Holiday Letter Feb 11th thru Mar 15th 2020	5	0	45	Weather - 2/17, 2/18, 2/23, 2/24, 2/25, 2/27, 4/8, 4/9, 4/10 and Holiday - 0
Weather / Holiday Letter Mar 16th thru Apr 15th 2020	7	0	52	Weather - 4/8, 4/10, 4/13, 4/14, 4/16, 4/17 and Holiday - 0
Weather / Holiday Letter Apr 20th thru May 17th 2020	3	0	55	Weather - 4/20, 4/23, 4/30 and Holiday - 0
Weather / Holiday Letter May 18th thru Jun 14th 2020	5	1	62	Weather - 5/26, 5/27, 6/4, 6/8, 6/9 and Holiday - 5/23, 5/24, 5/25 (Memorial Day)
Weather / Holiday Letter Jun 15th thru Jul 14th 2020	1	2	70	Weather - 7/7 and Holiday - 7/3, 7/4 (Independence Day)
Weather / Holiday Letter Jul 20th thru Aug 16th 2020	0	0	70	Weather - 0 and Holiday - 0
Weather / Holiday Letter Aug 17th thru Sep 20th 2020	7	1	81	Weather - 8/24, 8/25, 8/8, 9/9, 9/10, 9/11, 9/17 and Holiday - 9/4, 9/5, 9/6, 9/7 (Labor Day)
Weather / Holiday Letter Sep 21st thru Oct 15th 2020	2	0	83	Weather - 10/5, 10/6 and Holiday - 0
Weather / Holiday Letter Oct 16th thru Nov 5th 2020	1	0	84	Weather - 10/21 and Holiday - 0
Weather / Holiday Letter Nov 6th thru Dec 13th 2020	6	2	92	Weather - 11/11, 11/11, 11/12, 11/30, 12/1, 12/2 and Holiday - 11/26, 11/27
Weather / Holiday Letter Dec 14th thru Jan 21st 2021	1	0	93	Weather - 12/16 and Holiday - 0
CO No. 4		5	98	

GOOGLE MAPS - PRIOR TO CONSTRUCTION



DURING CONSTRUCTION - 10/6/2020



DURING CONSTRUCTION - 10/6/2020



DURING INSTALLATION OF YARD DRAIN - 3/25/2021



DURING INSTALLATION OF YARD DRAIN - 3/25/2021

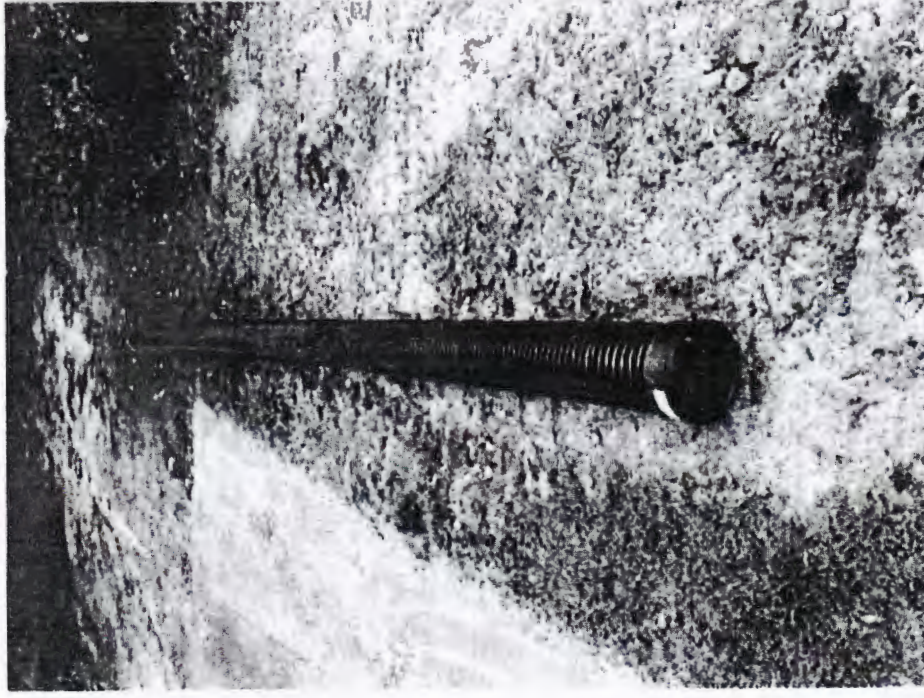
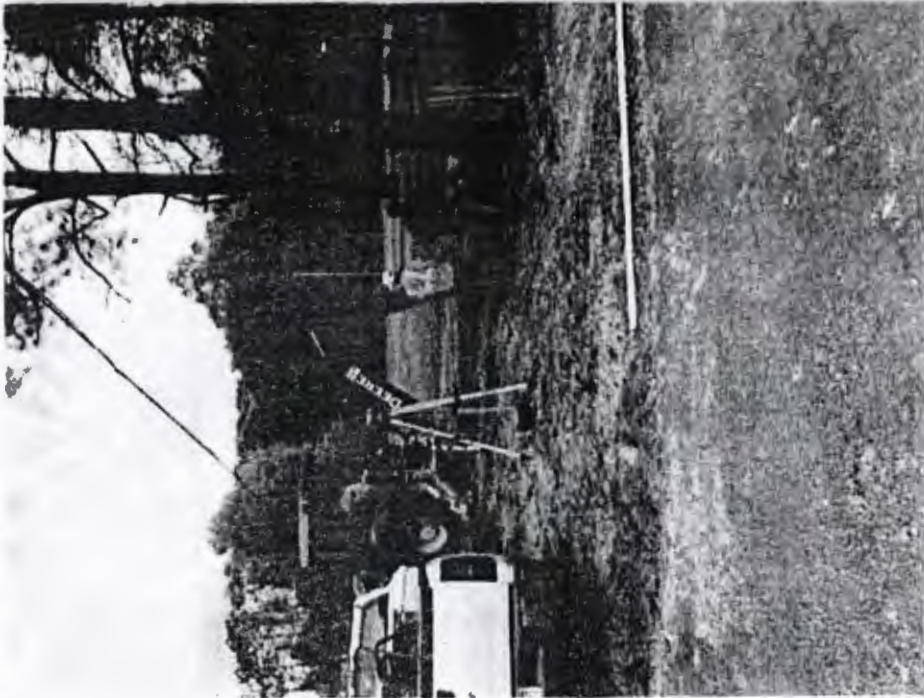

## DAILY REPORT OF CONSTRUCTION

FPN: N/A	Description: CR-115 (Old Dixie Hwy) from Bypass Road to Henry Smith Road		
FAN: N/A	Prime Contractor: Anderson Columbia Co., Inc.	NTP Date: 11/25/19	
Contract: CM2731	Project: NC19-015	<input type="checkbox"/> PRIME daily	Contract Days: 295

	LABOR	#	Hours	EQUIPMENT	#	Hours	ACTIVITIES OBSERVED
<b>CREW 1</b>	Superintendent	1	10	Backhoe, Track			MOT -Anderson Columbia Contractor on site performing single lane one way road closure at the following locations and times: MOT Crew # 1 Contractor on site performing single lane one way road closure from Sta.26+00 to Sta.15+00 LT/RT 8:00 am to 11:45 am Sta.121+00 to Sta.150+00 RT/LT 11:45 am to 1:45 pm Sta.180+00 to Sta.250+00 LT/RT 1:45 pm to 5:30 pm  Superintendent, foreman, and skilled laborer on site to perform clean up operations and man Water Truck on site desilting drain pipes. Pipes have silt remaining after desilting operation
	Foreman	1	10	Front End Loader			
	Skilled	3	10	Misc, Hand Tools			
	Semi-Skilled			Truck, Pickup	2	10	
	Common	8	10				
	Trainee						
	Common						
				Water Truck	1	10	
<b>CREW 2</b>	Superintendent			Truck, Flatbed	1	8	-Anderson Columbia Contractor on site performing Yard Drain installation.  Contractor excavated the existing material between 18+92 to 18+97 RT in the area side drain facilitate placement of yard drain. Sawcut an opening in the new side drainpipe installed 5' section of 8" pipe. Bricked and mortar the opening of the adjoining pipes.
	Foreman	1	8	Truck, Flatbed	1	8	
	Skilled	2	8	Front End Loader	1	8	
	Semi-Skilled						
	Common	2	8				
	Trainee						
	Common						
<b>CREW 3</b>	Superintendent						
	Foreman						
	Skilled						
	Semi-Skilled						
	Common						
	Trainee						

Inspector: Joseph Hanifen	Date: 03/25/21 (Thu)	Contract Day: 487
---------------------------	----------------------	-------------------

**From:** Davis, Dana W  
**Sent:** Wednesday, March 3, 2021 3:27 PM  
**To:** Joshua McDougal  
**Cc:** Ramsey French; Robert Companion; Brown, Robert Scott; Glennon, William M.; Martin, Mary; Hanifen, Joseph L.; Barton, Austin G.  
**Subject:** RE: DRAINAGE CONCERN- 18+85 RT.; CR-115 (Old Dixie Hwy) from Bypass Road to Henry Smith Road

**SUBJECT** **DRAINAGE CONCERN- 18+85 RT.**  
Job Description: CR-115 (Old Dixie Hwy) from Bypass Road to Henry Smith Road  
Financial Project Number: 432767-1-54-01  
Federal Aid Project Number: N/A  
Contract Number: CM2731  
County - Section Number: Nassau

Attn: Joshua McDougal, Project Manager  
Anderson Columbia Co., Inc.

After discussion with NC and a follow up with the property owner please proceed with installation of the yard drain from the ROW and connecting into the new 24" RCP as follows:

- Excavate the existing fill between 18+92 to 18+97 RT in the area above the side drain and between the ROW to facilitate placement of yard drain
  - Coordinate with Windstream (and other utility owners) to identify, locate, and protect existing facilities within ROW at location of excavation
- Sawcut an opening in the top right quadrant of the new side drain at approx. 18+95 RT. with adequate space to tie in an 8" yard drain pipe
- Add a 4' - 5' section of 8" HDPE pipe to create a yard drain from ROW and tie to the new side drain pipe at approx. 18+95 RT.
  - yard drain to be placed with a flowline elevation (FL) at ROW of 17.75' and FL at intersection of new side drain of 17.20'
- Brick and mortar the opening of the adjoining pipes and pour a concrete collar according to the detail below
- Replace excavated backfill over the yard drain connection and restore to plan grade



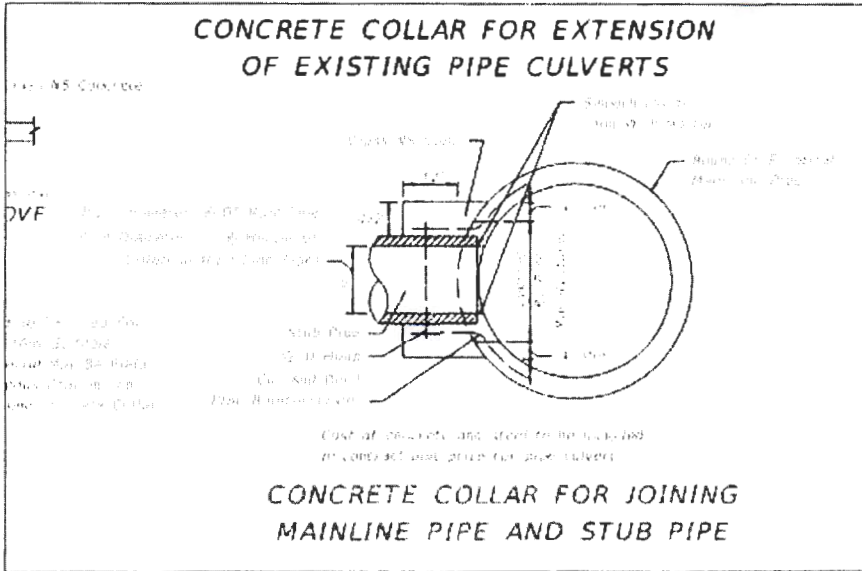

The price of \$5,51.76 and 5 days provided to perform this modification has been reviewed and accepted. Please proceed with scheduling and completion of the work.

Feel free to call if you have any questions.

Thanks,

Dana Davis  
Project Administrator  
**CDM Smith**  
7029-1 Commonwealth Ave.  
Jacksonville, FL. 32220  
(904)781-8131 Office  
(904)233-1292 Mobile  
[davisdw@cdmsmith.com](mailto:davisdw@cdmsmith.com)



**From:** Joshua McDougal <[Joshua.McDougal@andersoncolumbia.com](mailto:Joshua.McDougal@andersoncolumbia.com)>  
**Sent:** Tuesday, February 23, 2021 10:08 AM  
**To:** Davis, Dana W <[davisdw@cdmsmith.com](mailto:davisdw@cdmsmith.com)>  
**Subject:** RE: DRAINAGE CONCERN- 18+85 RT.; CR-115 (Old Dixie Hwy) from Bypass Road to Henry Smith Road

Dana,

The estimated cost for the installation and modification of the yard drain is \$5,151.76. Also we would like 5 additional days to be added to the contract for this work.



**Joshua O. McDougal**

Mobile: 386-623-2267

Office: 386-752-7585; EXT 215

P.O. Box 1829 Lake City, FL. 32056

**From:** Davis, Dana W <davisdw@cdmsmith.com>

**Sent:** Friday, February 12, 2021 7:48 AM

**To:** Joshua McDougal <Joshua.McDougal@andersoncolumbia.com>

**Cc:** Ramsey French <Ramsey.French@andersoncolumbia.com>; Robert Companion <rcompanion@nassaucountyfl.com>; Brown, Robert Scott <brownrs@cdmsmith.com>; Glennon, William M. <glennonwm@cdmsmith.com>; Martin, Mary <martinmj@cdmsmith.com>; Hanifen, Joseph L. <hanifenjl@cdmsmith.com>; Barton, Austin G. <bartonag@cdmsmith.com>; Watson, Dalton T. <watsondt@cdmsmith.com>

**Subject:** DRAINAGE CONCERN- 18+85 RT.; CR-115 (Old Dixie Hwy) from Bypass Road to Henry Smith Road

CAUTION: This email originated from outside your organization. Exercise caution when opening attachments or clicking links, especially from unknown senders.

<b>SUBJECT</b>	<b>DRAINAGE CONCERN- 18+85 RT.</b>
Job Description:	CR-115 (Old Dixie Hwy) from Bypass Road to Henry Smith Road
Financial Project Number:	432767-1-54-01
Federal Aid Project Number:	N/A
Contract Number:	CM2731
County - Section Number:	Nassau

Attn: Joshua McDougal, Project Manager  
Anderson Columbia Co., Inc.

A drainage concern related to an adjacent property has been identified due to the construction of a continuous run of side drain pipe encapsulating two adjacent driveways between 18+40+/- to 19+30+/- RT. (See attached Plan Sheets 24 and 102 for reference). In an effort to resolve this concern please investigate the location and provide a price to place a yard drain from the ROW and connecting into the new 24" RCP as follows:

- Excavate the existing fill between 18+82 to 18+87 RT in the area above the side drain and between the ROW to facilitate placement of yard drain

- Sawcut an opening in the top right quadrant of the new side drain at approx. 18+85 RT. with adequate space to tie in an 8" yard drain pipe
- Add a 4'- 5' section of 8" HDPE pipe to create a yard drain from ROW and tie to the new side drain pipe at approx. 18+85 RT.
  - yard drain to be placed with a flowline elevation (FL) at ROW of 18.00' and FL at intersection of new side drain of 17.25'
- Brick and mortar the opening of the adjoining pipes and pour a concrete collar according to the detail below
- Replace excavated backfill over the yard drain connection

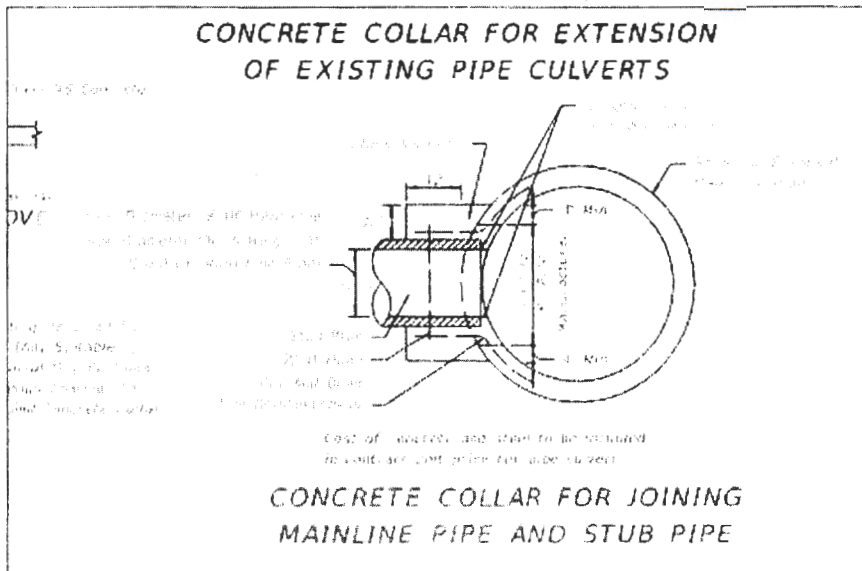

Please provide a price and schedule to complete this work as soon as reasonably possible.

Please feel free to call if you have any questions.

Thanks,

Dana Davis  
Project Administrator  
**CDM Smith**  
7029-1 Commonwealth Ave.  
Jacksonville, FL. 32220  
(904)781-8131 Office  
(904)233-1292 Mobile  
[davisdw@cdmsmith.com](mailto:davisdw@cdmsmith.com)



CONSTRUCTION

**From:** Paul@eltonalan.com  
**Sent:** Monday, December 21, 2020 2:46 PM  
**To:** Davis, Dana W  
**Cc:** mike@eltonalan.com; Robert Companion; Glennon, William M.; Brown, Robert Scott; Martin, Mary; Hanifen, Joseph L.; Barton, Austin G.  
**Subject:** RE: Citizen Complaint, CR-115 (Old Dixie Hwy) from Bypass Road to Henry Smith Road

Dana,

We agree with your solution of adding a yard drain to resolve the resident's complaint. Let me know if you need anything from us.

Thanks,

Paul Doherty  
Senior Designer



3653 Regent Blvd #606  
Jacksonville, FL 32224  
cell: 904-910-2132  
email: [Paul@eltonalan.com](mailto:Paul@eltonalan.com)  
web: [www.eltonalan.com](http://www.eltonalan.com)

**From:** Davis, Dana W <[davisdw@cdmsmith.com](mailto:davisdw@cdmsmith.com)>  
**Sent:** Thursday, December 17, 2020 1:13 PM  
**To:** [Paul@eltonalan.com](mailto:Paul@eltonalan.com)  
**Cc:** [mike@eltonalan.com](mailto:mike@eltonalan.com); Robert Companion <[rcompanion@nassaucountyfl.com](mailto:rcompanion@nassaucountyfl.com)>; Glennon, William M. <[glennonwm@cdmsmith.com](mailto:glennonwm@cdmsmith.com)>; Brown, Robert Scott <[brownrs@cdmsmith.com](mailto:brownrs@cdmsmith.com)>; Martin, Mary <[martinmj@cdmsmith.com](mailto:martinmj@cdmsmith.com)>; Hanifen, Joseph L. <[hanifenjl@cdmsmith.com](mailto:hanifenjl@cdmsmith.com)>; Barton, Austin G. <[bartonag@cdmsmith.com](mailto:bartonag@cdmsmith.com)>  
**Subject:** FW: Citizen Complaint, CR-115 (Old Dixie Hwy) from Bypass Road to Henry Smith Road

<b>SUBJECT</b>	<b>CITIZEN COMPLAINT- DRAINAGE CONCERN ISSUE 1 OF 2</b>
Job Description:	CR-115 (Old Dixie Hwy) from Bypass Road to Henry Smith Road
Financial Project Number:	432767-1-54-01
Federal Aid Project Number:	N/A
Contract Number:	CM2731
County - Section Number:	Nassau

Attn: Paul Doherty, Senior Designer  
Elton Alan Consulting Engineers

Please see below and attached for your review and comments on how we should proceed/address.

Thanks,

Dana Davis  
Project Administrator  
**CDM Smith**  
7029-1 Commonwealth Ave.  
Jacksonville, FL 32220  
(904)781-8131 Office  
(904)233-1292 Mobile  
[davisdw@cdmsmith.com](mailto:davisdw@cdmsmith.com)

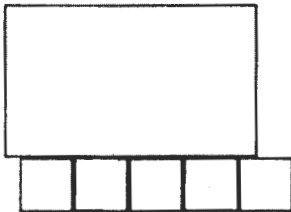

**From:** Davis, Dana W <[davisdw@cdmsmith.com](mailto:davisdw@cdmsmith.com)>  
**Sent:** Wednesday, November 18, 2020 12:22 PM  
**To:** Glennon, William M. <[glennonwm@cdmsmith.com](mailto:glennonwm@cdmsmith.com)>  
**Cc:** Martin, Mary <[martinmj@cdmsmith.com](mailto:martinmj@cdmsmith.com)>; Barton, Austin G. <[bartonag@cdmsmith.com](mailto:bartonag@cdmsmith.com)>; Hanifen, Joseph L. <[hanifenjl@cdmsmith.com](mailto:hanifenjl@cdmsmith.com)>; Brown, Robert Scott <[brownrs@cdmsmith.com](mailto:brownrs@cdmsmith.com)>  
**Subject:** RE: Citizen Complaint, CR-115 (Old Dixie Hwy) from Bypass Road to Henry Smith Road

<b>SUBJECT</b>	<b>Citizen Complaint</b>
Job Description:	CR-115 (Old Dixie Hwy) from Bypass Road to Henry Smith Road
Financial Project Number:	432767-1-54-01
Federal Aid Project Number:	N/A
Contract Number:	CM2731
County - Section Number:	Nassau

Attn: Bill Glennon, CDM Smith

As a follow up to the below citizen complaint the team and I reviewed this location and took elevation shots between the two driveways and to verify the flowline of the side drain pipe placed at this location. According to the shots taken in the field the flowline at the North end of the pipe matched the plan elevation. Shots taken between the driveway indicated the following elevations:

- At ROW: El.= 18.52'
- At 13' o/s Rt. El.= 18.06'
- At 25' o/s Rt. El.= 17.99'

The above elevations would be consistent with the cross-section indicated at 18+63 (Plan Sheet 102).

It was confirmed in the field that an existing yard drain did not exist in this location prior to construction. Through conversation with the adjacent property owner (Mr. Hodge) it was determined that prior to construction the property owner dug a small trench at the joining property line of neighboring property out to the existing ditch at this location to relieve the standing water from their properties.

My original recommendation was to possibly add a 4' section of 8" HDPE pipe to create a yard drain from ROW and tie to the new side drain pipe. In order for this recommendation to work it would require the yard drain to be placed with a flowline elevation (FL) at ROW of 18.00' and FL at intersection of new side drain of 17.25'.

The concerns with placing a yard drain as originally recommended at this location are as follows:

- Property owners would have to maintain a "swale" or trench on their properties leading to yard drain.
- Due to the flow line of yard drain (17.25') at the pipe connection the capacity could possibly be reduced by almost 40% which during heavy or long periods of rain may result in hydraulic pressure pushing water out of the yard drain onto the adjacent properties.
- Could result in long term maintenance issues/concerns.

Please review and let me know your thoughts on how we should proceed/address.

Thanks,

Dana Davis  
Project Administrator  
**CDM Smith**  
7029-1 Commonwealth Ave.  
Jacksonville, FL. 32220  
(904)781-8131 Office  
(904)233-1292 Mobile  
[davisdw@cdmsmith.com](mailto:davisdw@cdmsmith.com)

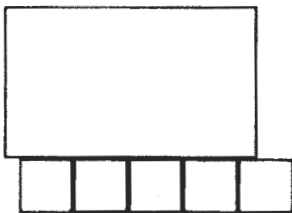

**From:** Glennon, William M. <[glennonwm@cdmsmith.com](mailto:glennonwm@cdmsmith.com)>  
**Sent:** Monday, October 12, 2020 1:30 PM  
**To:** Davis, Dana W <[davisdw@cdmsmith.com](mailto:davisdw@cdmsmith.com)>  
**Cc:** Martin, Mary <[martinmj@cdmsmith.com](mailto:martinmj@cdmsmith.com)>; Barton, Austin G. <[bartonag@cdmsmith.com](mailto:bartonag@cdmsmith.com)>; Hanifen, Joseph L. <[hanifenjl@cdmsmith.com](mailto:hanifenjl@cdmsmith.com)>  
**Subject:** RE: Citizen Complaint, CR-115 (Old Dixie Hwy) from Bypass Road to Henry Smith Road

Generally, in my experience yard drains won't be shown in the plans. However, if we encounter a yard drain on the right of way we need to tie it into our drainage system somehow in order to be good neighbors.

**Bill Glennon**  
CDM Smith  
904.781.8131 office  
904.383.9126 cell  
[cdmsmith.com](http://cdmsmith.com)

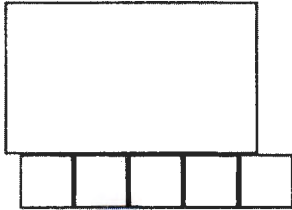

**From:** Davis, Dana W <[davidsw@cdmsmith.com](mailto:davidsw@cdmsmith.com)>  
**Sent:** Monday, October 12, 2020 1:22 PM  
**To:** Glennon, William M. <[glennonwm@cdmsmith.com](mailto:glennonwm@cdmsmith.com)>  
**Cc:** Martin, Mary <[martinmj@cdmsmith.com](mailto:martinmj@cdmsmith.com)>; Barton, Austin G. <[bartonag@cdmsmith.com](mailto:bartonag@cdmsmith.com)>; Hanifen, Joseph L. <[hanifenjl@cdmsmith.com](mailto:hanifenjl@cdmsmith.com)>  
**Subject:** RE: Citizen Complaint, CR-115 (Old Dixie Hwy) from Bypass Road to Henry Smith Road

Bill,

I stand corrected, the driveways in question are on the Rt. side of roadway. I was comparing the X-sections on the left. Based on the X-sections (Plan Sheet 102) the existing property sloped away from the NC ROW prior to construction. The presence of an existing yard drain is not indicated at this location. Elevation shots at the existing edge of ROW (lowest point between driveways) and 10-20 ft. offset onto adjacent property may indicate this concern existed prior to construction.

Thanks,

Dana Davis  
Project Administrator  
**CDM Smith**  
7029-1 Commonwealth Ave.  
Jacksonville, FL. 32220  
(904)781-8131 Office  
(904)233-1292 Mobile  
[davidsw@cdmsmith.com](mailto:davidsw@cdmsmith.com)



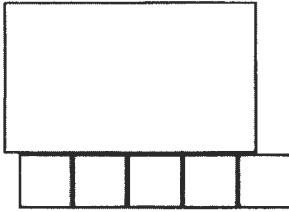

**From:** Glennon, William M. <[glennonwm@cdmsmith.com](mailto:glennonwm@cdmsmith.com)>  
**Sent:** Monday, October 12, 2020 12:35 PM  
**To:** Davis, Dana W <[davisdw@cdmsmith.com](mailto:davisdw@cdmsmith.com)>  
**Cc:** Martin, Mary <[martinmj@cdmsmith.com](mailto:martinmj@cdmsmith.com)>; Barton, Austin G. <[bartonag@cdmsmith.com](mailto:bartonag@cdmsmith.com)>; Hanifen, Joseph L. <[hanifenjl@cdmsmith.com](mailto:hanifenjl@cdmsmith.com)>  
**Subject:** RE: Citizen Complaint, CR-115 (Old Dixie Hwy) from Bypass Road to Henry Smith Road

I don't know that I agree the open ditch was eliminated. There wasn't enough room to place 2 MES between the properties so the EOR piped it.

Be that as it may, typically in the past in situations like this we tie the yard drain into the pipe and pour a collars per standard plans 430-001.

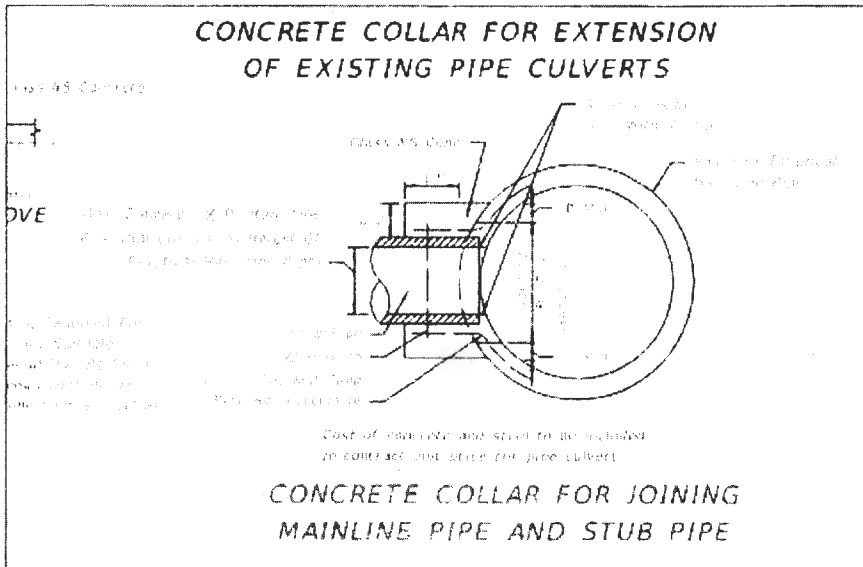

Please call if you have any questions.

**Bill Glennon**  
CDM Smith  
904.781.8131 office  
904.383.9126 cell  
[cdmsmith.com](http://cdmsmith.com)

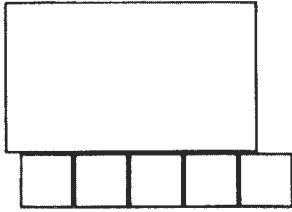

**From:** Davis, Dana W <[davisdw@cdmsmith.com](mailto:davisdw@cdmsmith.com)>  
**Sent:** Monday, October 12, 2020 11:32 AM  
**To:** Glennon, William M. <[glennonwm@cdmsmith.com](mailto:glennonwm@cdmsmith.com)>  
**Cc:** Martin, Mary <[martinmj@cdmsmith.com](mailto:martinmj@cdmsmith.com)>  
**Subject:** FW: Citizen Complaint, CR-115 (Old Dixie Hwy) from Bypass Road to Henry Smith Road

Bill,

Based on the X-sections (Plan Sheet 102) the existing property sloped toward the NC ROW prior to construction. Drainage at this location was constructed according to the Contract Plans. Would you like to send this back to the EOR for comment?

Thanks,

Dana Davis  
Project Administrator  
**CDM Smith**  
7029-1 Commonwealth Ave.  
Jacksonville, FL. 32220  
(904)781-8131 Office  
(904)233-1292 Mobile  
[davisdw@cdmsmith.com](mailto:davisdw@cdmsmith.com)

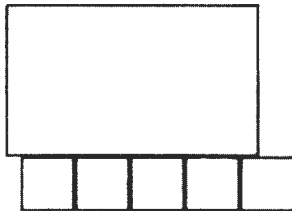

**From:** Barton, Austin G. <[bartonag@cdmsmith.com](mailto:bartonag@cdmsmith.com)>  
**Sent:** Friday, October 9, 2020 4:35 PM  
**To:** Glennon, William M. <[glennonwm@cdmsmith.com](mailto:glennonwm@cdmsmith.com)>  
**Cc:** Davis, Dana W <[davisdw@cdmsmith.com](mailto:davisdw@cdmsmith.com)>; Hanifen, Joseph L. <[hanifenjl@cdmsmith.com](mailto:hanifenjl@cdmsmith.com)>; Martin, Mary <[martinmj@cdmsmith.com](mailto:martinmj@cdmsmith.com)>  
**Subject:** Citizen Complaint, CR-115 (Old Dixie Hwy) from Bypass Road to Henry Smith Road

**SUBJECT**

**Citizen Complaint**

Job Description: CR-115 (Old Dixie Hwy) from Bypass Road to Henry Smith Road  
Financial Project Number: 432767-1-54-01  
Federal Aid Project Number: N/A  
Contract Number: CM2731  
County - Section Number: Nassau

Attn: Bill Glennon, CDM Smith

During today's operations I was approached by Sylvia Hodge, the resident of 450476 Old Dixie Highway. Mrs. Hodge explained to me that the low lying area between her property and her next door neighbor's is flooding as a result of our project. What she is referring to is the side drain placed from Sta. 18+44.12 to Sta. 19+26.05 RT in which the open ditch between the two driveways was removed to allow for one continuous pipe run. This side drained was not broken up into two separate runs in a field change like a few other areas on the project because there is not a clear swale between the two properties draining into the county ditch.

Attached to this email is a photo Mrs. Hodge provided to me during our discussions on today's date. The photo shows the area in question on this past Tuesday, October 6<sup>th</sup> 2020, which was the end of what was a good stretch of wet weather. Mrs. Hodge claims that this flooding is significantly more than before construction, but she did not provide me with, nor did I have in my records, any photos of the area after a rain before the side drain was placed (attached is the google maps view from January 2019 but does not appear to have rained recently). However, just upon visual inspection it does appear to me that this area is susceptible to flooding due to how far below the roadway it is and its proximity to both properties' driveways which will always drain water towards the residences due to them being on a slope. I have attached two photos from today's date in order to show the sloping nature of the driveways and current field conditions of the area. I have also attached the plan view and cross section plan sheets for this specific area to this email to show that field matches the planned design.

Resident's Contact Information: Sylvia Hodge, 904-304-7077

While I did not include Anderson Columbia in this email I did notify the Superintendent of this complaint verbally in the field on today's date.

Please let me know if you have any questions, thank you

**Austin Barton**

904.431.8197

[bartonag@cdmsmith.com](mailto:bartonag@cdmsmith.com)

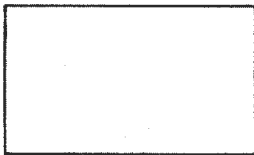

EROSION CONTROL PLANS ARE DESIGNED TO SHOW INTENT OF APPLICATION ONLY. CONTRACTOR SHALL BE RESPONSIBLE FOR MAKING CHANGES WHERE APPLICABLE BASED ON ACTUAL FIELD CONDITIONS AT THE TIME OF INSTALLATION. ALL INSTALLATIONS SHALL BE IN ACCORDANCE WITH "STATE OF FLORIDA EROSION AND SEDIMENT CONTROL".

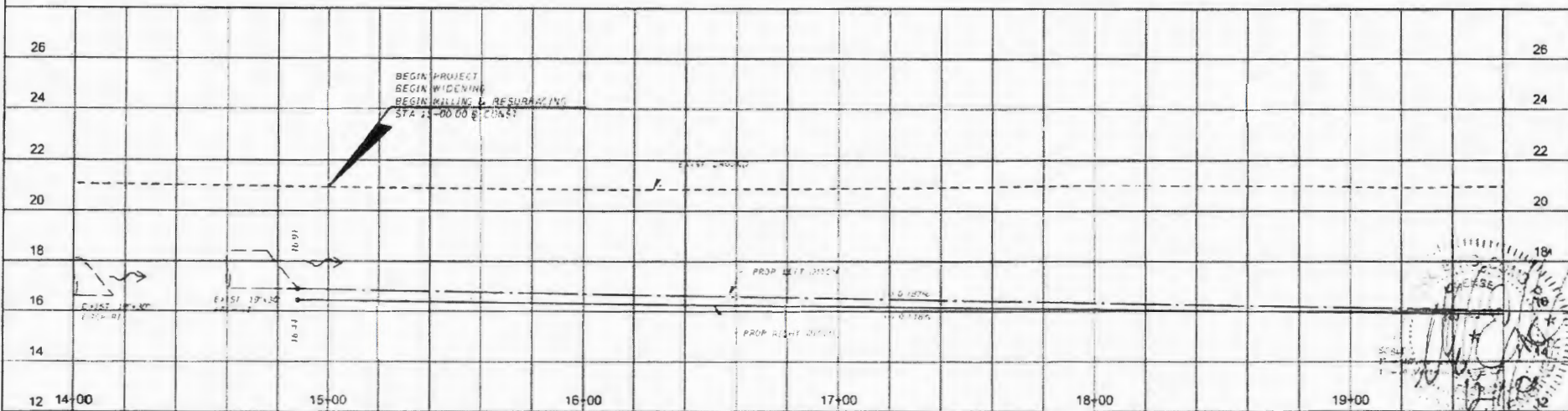
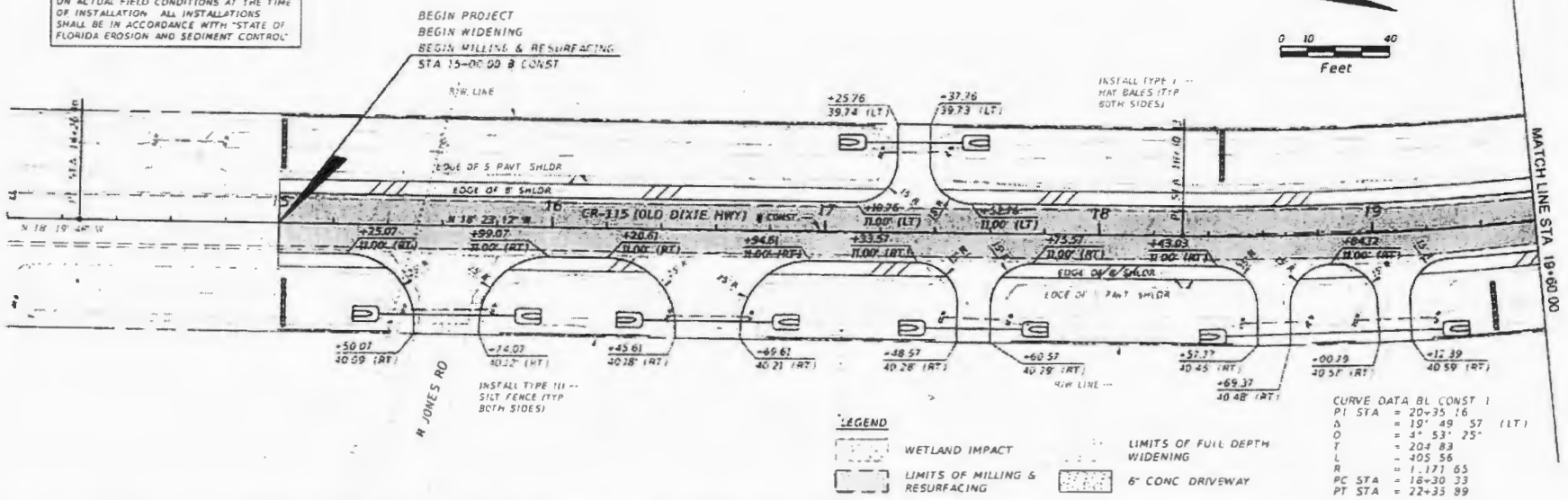
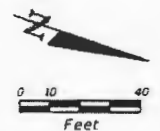

DATE	DESCRIPTION	DATE	DESCRIPTION

Engineer of Record  
**EltonAlan**  
 Consulting Engineers | General Contractors  
 Certificate of Registration No. 70320



**NASSAU COUNTY ENGINEERING**  
 CONSTRUCTION PLANS FOR  
**CR 115 WIDENING AND RESURFACING**

**ROADWAY PLAN-PROFILE**

SHEET NO  
 24

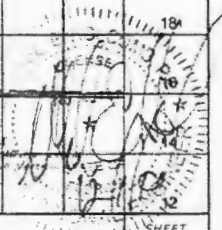

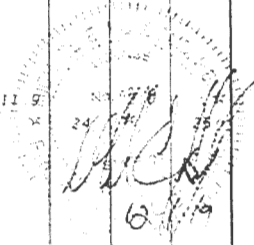
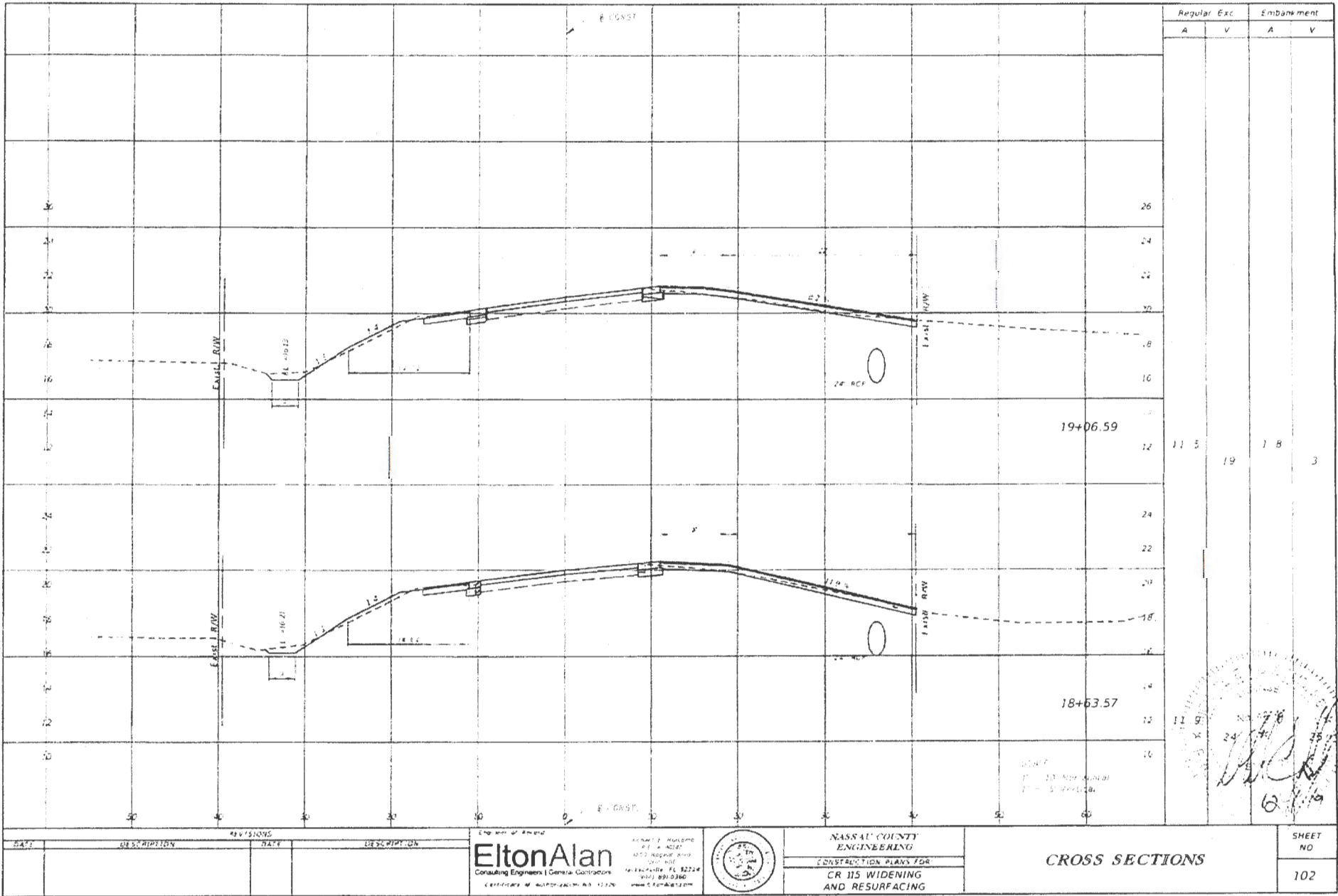

<b>Elton Alan</b> Consulting Engineers & General Contractors 1555 Reggae Blvd Ft. Lauderdale, FL 33324 Phone: 954-336-0360 www.EltonAlan.com			<b>NASSAU COUNTY ENGINEERING</b> CONSTRUCTION PLANS FOR <b>CR 115 WIDENING AND RESURFACING</b>	<b>CROSS SECTIONS</b> SHEET NO <b>102</b>
---	--	--	--	---

**Certificate Of Completion**

Envelope Id: 9E6178EDF53C431F891D654EFF80F4E3

Subject: Please DocuSign: CM2731-CO04Amended.pdf

Source Envelope:

Document Pages: 21

Signatures: 5

Certificate Pages: 3

Initials: 0

AutoNav: Enabled

Envelope Stamping: Enabled

Time Zone: (UTC-05:00) Eastern Time (US &amp; Canada)

Status: Completed

Envelope Originator:

Amber Carter

acarter@nassaucountyfl.com

IP Address: 50.238.237.26

**Record Tracking**

Status: Original

6/2/2021 4:19:48 PM

Holder: Amber Carter

acarter@nassaucountyfl.com

Location: DocuSign

**Signer Events**

Robert Companion

RCompanion@nassaucountyfl.com

County Engineer

Nassau County BOCC

Security Level: Email, Account Authentication  
(None)**Signature**

Signature Adoption: Pre-selected Style

Using IP Address: 50.238.237.26

**Timestamp**

Sent: 6/2/2021 4:28:23 PM

Viewed: 6/2/2021 5:25:05 PM

Signed: 6/2/2021 5:25:18 PM

**Electronic Record and Signature Disclosure:**

Not Offered via DocuSign

Brian Simmons

bsimmons@nassaucountyfl.com

Procurement Manager

Nassau County BOCC

Security Level: Email, Account Authentication  
(None)

Signature Adoption: Uploaded Signature Image

Using IP Address: 50.238.237.26

Sent: 6/2/2021 5:25:22 PM

Viewed: 6/3/2021 7:44:14 AM

Signed: 6/3/2021 7:44:20 AM

**Electronic Record and Signature Disclosure:**

Not Offered via DocuSign

Megan Diehl

mdiehl@nassaucountyfl.com

OMB Director

Nassau County BOCC

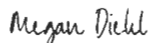
Security Level: Email, Account Authentication  
(None)

Signature Adoption: Pre-selected Style

Using IP Address: 50.238.237.26

Sent: 6/3/2021 7:44:22 AM

Viewed: 6/3/2021 10:23:17 AM

Signed: 6/3/2021 11:01:14 AM

**Electronic Record and Signature Disclosure:**

Not Offered via DocuSign

Michael S. Mullin

mmullin@nassaucountyfl.com

County Attorney

Nassau County BOCC

Security Level: Email, Account Authentication  
(None)

Signature Adoption: Pre-selected Style

Using IP Address: 50.238.237.26

Sent: 6/3/2021 11:01:16 AM

Viewed: 6/3/2021 1:55:12 PM

Signed: 6/3/2021 1:55:21 PM

**Electronic Record and Signature Disclosure:**

Not Offered via DocuSign

**Signer Events**

Taco E. Pope, AICP  
 tpope@nassaucountyfl.com  
 County Manager  
 Nassau County BOCC

Security Level: Email, Account Authentication  
 (None)

**Electronic Record and Signature Disclosure:**  
 Not Offered via DocuSign

**In Person Signer Events****Editor Delivery Events****Agent Delivery Events****Intermediary Delivery Events****Certified Delivery Events****Carbon Copy Events**

Amber Carter  
 acarter@nassaucountyfl.com  
 Nassau County BOCC

Security Level: Email, Account Authentication  
 (None)

**Electronic Record and Signature Disclosure:**  
 Not Offered via DocuSign

Robert Companion  
 RCompanion@nassaucountyfl.com  
 County Engineer  
 Nassau County BOCC

Security Level: Email, Account Authentication  
 (None)

**Electronic Record and Signature Disclosure:**  
 Not Offered via DocuSign

Shelley Caldwell  
 scaldwell@nassaucountyfl.com  
 Nassau County BOCC

Security Level: Email, Account Authentication  
 (None)

**Electronic Record and Signature Disclosure:**  
 Not Offered via DocuSign

Brenda Linville  
 blinville@nassauclerk.com  
 Nassau County Clerk

Security Level: Email, Account Authentication  
 (None)

**Electronic Record and Signature Disclosure:**  
 Not Offered via DocuSign

Heather Nazworth  
 hnazworth@nassauclerk.com

Security Level: Email, Account Authentication  
 (None)

**Electronic Record and Signature Disclosure:**  
 Not Offered via DocuSign

**Signature**

*Taco E. Pope AICP*

Signature Adoption: Pre-selected Style  
 Using IP Address: 107.77.215.10  
 Signed using mobile

**Signature****Status****Status****Status****Status****Status**

**COPIED**

**COPIED**

**COPIED**

**COPIED**

**COPIED**

**Timestamp**

Sent: 6/3/2021 1:55:24 PM  
 Viewed: 6/3/2021 2:15:09 PM  
 Signed: 6/3/2021 2:16:37 PM

**Timestamp****Timestamp****Timestamp****Timestamp****Timestamp****Timestamp**

Sent: 6/3/2021 2:16:39 PM

Sent: 6/3/2021 2:16:39 PM

Sent: 6/3/2021 2:16:40 PM

Sent: 6/3/2021 2:16:41 PM

Sent: 6/3/2021 2:16:42 PM

### Carbon Copy Events

Melissa Lucey

mlucey@nassauclerk.com

Security Level: Email, Account Authentication  
(None)

**Electronic Record and Signature Disclosure:**

Not Offered via DocuSign

Peggy Snyder

psnyder@nassauclerk.com

Security Level: Email, Account Authentication  
(None)

**Electronic Record and Signature Disclosure:**

Not Offered via DocuSign

Tina Barnett

tbarnett@nassauclerk.com

Security Level: Email, Account Authentication  
(None)

**Electronic Record and Signature Disclosure:**

Not Offered via DocuSign

Jennifer Marlatt

jmarlatt@nassauclerk.com

Security Level: Email, Account Authentication  
(None)

**Electronic Record and Signature Disclosure:**

Not Offered via DocuSign

### Witness Events

### Notary Events

### Envelope Summary Events

Envelope Sent

Certified Delivered

Signing Complete

Completed

### Payment Events

### Status

**COPIED**

**COPIED**

**COPIED**

**COPIED**

### Signature

### Signature

### Status

Hashed/Encrypted

Security Checked

Security Checked

Security Checked

### Status

### Timestamp

Sent: 6/3/2021 2:16:44 PM

Sent: 6/3/2021 2:16:45 PM

Sent: 6/3/2021 2:16:46 PM

Sent: 6/3/2021 2:16:47 PM

### Timestamp

### Timestamp

### Timestamps

6/2/2021 4:28:23 PM

6/3/2021 2:15:09 PM

6/3/2021 2:16:37 PM

6/3/2021 2:16:47 PM

### Timestamps